

THETA

Vertical multi-lane high speed sachet machines

-  POWDERS
-  GRANULES
-  PASTES
-  LIQUIDS
-  TABLETS

since 1965



www.universalpack.it

 MADE IN ITALY

THETA Sachet Machines

AUTOMATIC MULTI-LANE HIGH SPEED SACHET MACHINES THETA RANGE for food, pharmaceutical, chemical and cosmetic market

THETA is the new Universal Pack's continuous motion machine to produce 4 side seal sachets. It can be equipped with any dosing system and can accommodate a large range of sachet sizes.

Innovative sealing system, based on protracted contact between sealable laminates and sealing jaws, ensures optimal quality and aesthetically first class sachets at the highest output.

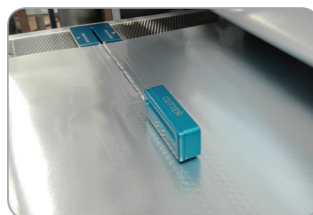
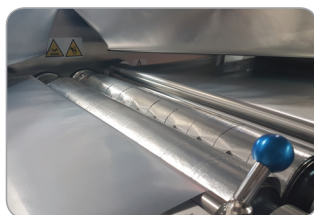

Developing the latest packaging technology since 1965

DOSING SYSTEMS

BASCULATING

For free flowing products

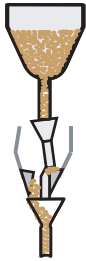

AUGER

For powders, free and non free flowing products



PISTON PUMP

For pasty products

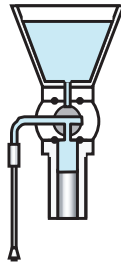

GRAVIMETRIC

For liquid products



ALIGNER DISPENSER

For tablets and similar products

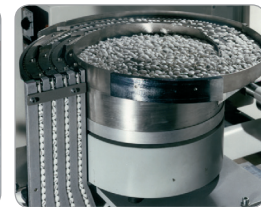
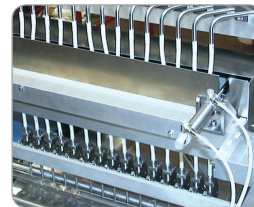
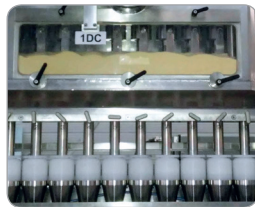
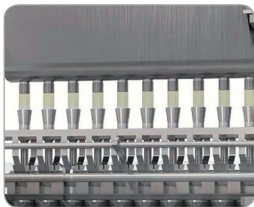
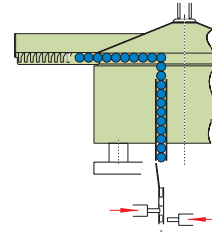

TECHNICAL DATA

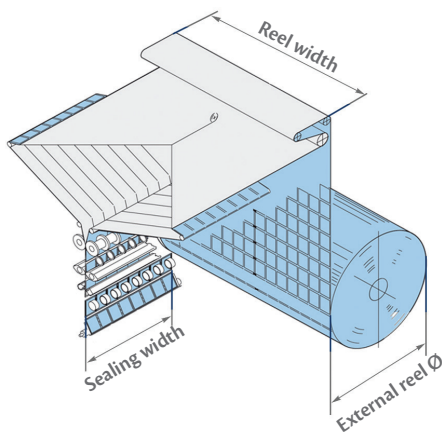

SACHET	Min.	Max
Width [mm]	25	100
Length [mm]	50	200
Dose [cm ³]	0,1	100

PRODUCTIVITY	
Output	up to 4000 sachets/min
Lanes	from 4 to 20

REEL		
Max width [mm]		1200
External Ø [mm]		800

SIZE		
Width [mm]		2000
Length [mm]		2700
Height [mm]		2600



Ergonomic design and space optimization

Synchronised brushless servomotors

Component codification

High resolution HMI with tutorials

Quick reel splicing in an easily accessible position

Film tension control, automatic reel alignment

Ink jet, Thermo Transfer, Embossing and Laser printing

Inline sachet check-weighing with trend control feed-back

Remote service assistance

Consolidated experience in high-quality sachet machinery

Synthesis THETA Complete Automatic Lines

MAXIMUM FLEXIBILITY

Tool free disassembly
Modular change over

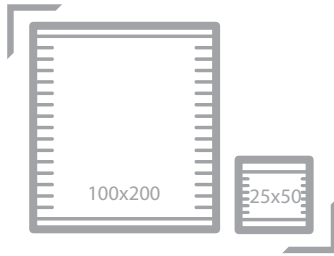

WCM

World Class Machine: robust, precise, flexible, reliable, ergonomic, accessible, user-friendly, low maintenance required.

HYGIENE

Designed according to pharmaceutical industry highest hygienic standards in compliance with Hygienic Design regulations.

INDUSTRY 4.0

Ready to be installed in a 4.0 environment. Provided with wi-fi and RJ 45 port to communicate with the supervisor for remote diagnosis.

ACCESSIBILITY

The main components are highly accessible. The doser can be easily moved out of the machine's frame to facilitate its cleaning.

Over 50 years of experience in packaging manufacturing



HIGH SPEED

Thanks to the best combination between the advantages of continuous and intermittent motion.

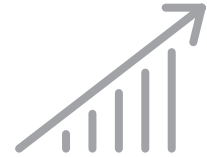

ENERGY

Designed to run with low energy. It is also possible to monitor electrical and pneumatic consumption by means of the HMI.

MODULARITY

Designed and constructed combining numerous modules. This concept enhances machine's versatility allowing a quick and easy format change.

MAINTENANCE

Robust machine very easy to maintain (TPM) built to run 24/7 with a minimal number of consumable spare parts.

COMPLETE LINE

Transfer and linkage systems to connect with Universal Pack secondary packaging solutions and to provide turn-key complete packaging lines.

High efficiency, flexibility and user-friendly solutions

Universal Pack's mission

NICE TO MEET YOU

Universal Pack presents itself as a designer and constructor of highly efficient, flexible and user-friendly sachet machinery and complete lines, totally client-oriented. All these packaging solutions are designed, manufactured and assembled inhouse in the factory in Italy, which means Universal Pack is responsible to ensure the functioning of the complete line.

In over 50 years, we have gained the experience and knowledge necessary to produce machines for all industry sectors: food, pharmaceutical, nutraceutical, chemical and cosmetics.

The choice is yours.



EXPERIENCE



RELIABILITY



EFFICIENCY



BESPOKE SOLUTIONS



CUSTOMER SERVICE



PROJECT MANAGEMENT



After sale service



Assembly department



Headquarter

Entirely made in house with state-of-the-art technology



CNC tooling machinery

Project management

The worldwide references are Universal Pack's strength

www.universalpack.it



UNIVERSAL PACK S.r.l.
Via Vivare 425, 47842
San Giovanni in Marignano (Rimini) - Italy
Tel. +39 0541 955 276 - Fax +39 0541 955 400
www.universalpack.it - info@universalpack.it

